



## Video Measuring Microscope for precision 3-axis measurement

- 50 years of proven optical experience, packed into a powerful 3-axis non-contact video measuring system
- High accuracy, value-for-money system
- Powerful and intuitive with amazing simplicity
- Compact, robust system with small footprint

# 3-Axis Video Measuring Microscope

Vision Engineering's Falcon incorporates over 50 years of proven optical experience, in a powerful 3-axis non-contact measuring system. Falcon delivers cost-effective, accurate results, with amazing simplicity.

Vision Engineering has packed massive technical capabilities into a small and compact system, yet Falcon is suitable for both shop-floor quality control and manufacturing inspection applications. From simple, single-feature operation to multi-point video edge detection, Falcon delivers accurate and repeatable results in 3 axes for a wide range of precision measuring applications.

- High repeatable accuracy 3-axis measuring system
- 'Best-in-class' performance, with advanced capabilities, as standard
- Powerful, intuitive and affordable, delivering accurate results, with confidence
- High resolution indexed zoom optics offer precision and flexibility
- Large field of view for easy sample orientation
- Progressive motorised Z-axis control

## Powerful but simple



The powerful and intuitive touch-screen video microprocessor is suitable for both multi-user shop-floor use and advanced manufacturing inspection applications.

## Fast but accurate



A high precision NLEC-calibrated\* measuring stage ensures accurate results in X & Y axes, with unique camera iris control ensuring superb accuracy and repeatability of Z-axis results.

## High Spec but affordable



From the start, Falcon was designed to fit your budget without compromising quality. Expect to pay more for comparable accuracy and specification systems.

## Features at a glance...

Camera/Optics		
Camera	High resolution colour CCD camera with 5:1 zoom ratio	
Camera Iris	5-position indexed camera iris allowing increased Z-axis accuracy and enhanced component edge definition	
Standard Magnification	10x - 50x	20x - 100x
Field of View	13.5 mm (max.)	6.75 mm (max.)
Zoom Indexing	Repeatable 5-position indexed zoom	

Measuring Stage		
	150mm x 100mm	150mm x 150mm
NLEC* Stage Calibration	Standard	Standard
X/Y Quick Release	-	Standard
Maximum Stage Load	10 kgs	15 kgs
Z-Axis Capacity	125 mm	115 mm
Z-Axis Control	Progressive motorised Z-axis for fine and rapid movement	

Illumination	
Surface	Controllable quadrant LED illumination for detection of low-contrast edges with high precision - long-life LEDs with 10,000+ hours illumination
Substage	Controllable LED illumination with 5-position indexed iris, for accurate profile measurement - long-life LEDs with 10,000+ hours illumination

Processor	
Part Programming	Programme a measurement sequence to measure the same points per feature, in the identical sequence, part after part.
Geometric Tolerancing	Easy-to-view graphical representation instantly views pass/fail performance details for critical part dimensions.
Image Capture	Image capture (in JPEG format) to either internal memory or directly to USB port.

Accessories	
Footswitch	'Plug & play' footswitch option for hands-free data entry

\*Non Linear Error Correction

### 'Best-in-class' performance

Compact with a small footprint, Falcon incorporates many advanced features designed to increase accuracy and simplify operation, delivering performance normally to be found with more expensive systems.

Falcon includes both surface and substage iris aperture control, motorised Z-axis movement, controllable quadrant LED illumination and both high and low magnification lens options as standard.

### Advanced zoom optics

Focusing on accuracy, Falcon employs high resolution zoom optics (up to 100x magnification) to provide enhanced component edge definition, with a unique indexed camera iris control allowing depth of field to be reduced, increasing accuracy and repeatability of Z-axis results. A large field of view (13.5mm max.) simplifies component location and orientation.

### Precision measuring stages

Falcon, complete with Vision Engineering's renowned precision measuring stages include factory-completed non-linear error correction (NLEC) calibration as standard to ensure optimum accuracy, traceable to international standards for the purposes of ISO9000.

### Edge detection/measurement tools

An advanced touch-screen colour video microprocessor provides an array of powerful video edge detection tools to speed up and simplify the measurement process, including crosshair, offset crosshair for difficult-to-find edges, manual or automatic single point detection and multi-point video edge detection for measurements both inside and outside the field of view.

### Controllable quadrant LED illumination

Controllable quadrant LED surface illumination optimises lighting conditions, enhancing edge definition, inclusions and fine scratches, with an indexed substage iris aperture allowing precise edge contrast of profiled and turned parts.

Fully controllable surface and substage illumination can be programmed as part of a measurement routine, ensuring accurate and repeatable measurements.

### Construction and ergonomics

Falcon's robust, dynamically engineered design reduces stress points to optimise accuracy. Rugged in construction, the sealed unit has been designed to cope with the demands of a busy production environment.

All controls feature a soft-touch silicone finish, ergonomically positioned to reduce head, hand and body movement and resulting fatigue.



## Measurement Uncertainty

Repeatable accuracy in X and Y axes, 4µm or better

- Uncertainty formula  $U_{95}2D = 3+(6L/1000)\mu\text{m}$   
where L = length in mm under controlled conditions

High performance Z-axis accuracy, varying according to subject, operator and conditions

## Video Camera

High resolution colour CCD camera with 5:1 ratio, 5-position indexed zoom and iris aperture control

## Optical Data

Zoom Magnification Range	10 - 50x	20 - 100x
Maximum field of view	13.5mm	6.75mm
Minimum field of view	2.7mm	1.35mm

## Illumination

- Quadrant controllable surface illumination provided by 20 (4 banks of 5) x high intensity LEDs (10,000+ hours)
- Controllable transmitted illumination provided by 1 x high intensity LED (10,000+ hours)

## Stage Capacities

- 150mm x 150mm x 115mm (15 kgs maximum load)
- 150mm x 100mm x 125mm (10 kgs maximum load)

## Encoder Resolution

X = 1µm Y = 1µm Z = 1µm

## Power

Power supply: 85 - 264V AC 47/63Hz

## System Weight

- Falcon with 150mm x 150mm stage 24.5 kgs
- Falcon with 150mm x 100mm stage 19 kgs



Precision manufactured in the EU

## Dimensions

- A = 286mm
- B = 220mm
- C = 220mm
- D = 410mm (150mm x 100mm stage)  
415mm (150mm x 150mm stage)
- E = 530mm (150mm x 100mm stage)  
535mm (150mm x 150mm stage)
- F = 530mm max.
- G = 125mm max. capacity (150mm x 100mm stage)  
115mm max. capacity (150mm x 150mm stage)

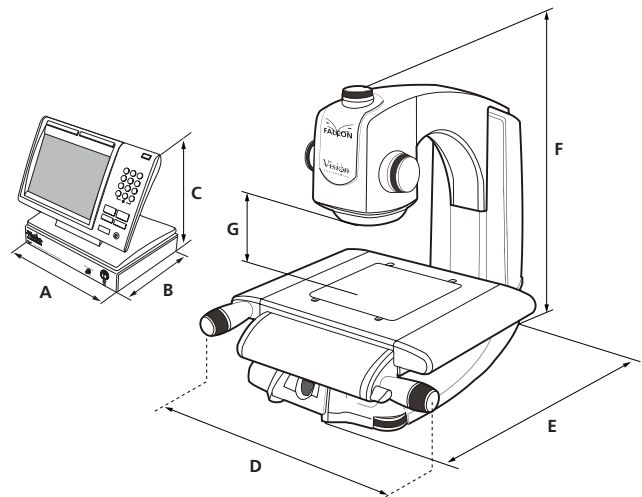

For more information...

Vision Engineering has a network of offices and technical distributors around the world. For more information, please contact your Vision Engineering branch, local authorised distributor, or visit our website.

Vision Engineering Ltd.  
**(Manufacturing)**  
Send Road, Send, Woking,  
Surrey, GU23 7ER, England  
Tel: +44 (0) 1483 248300  
Fax: +44 (0) 1483 223297  
Email: generalinfo@visioneng.com

Vision Engineering Inc.  
**(Manufacturing & Commercial)**  
570 Danbury Road, New Milford,  
CT 06776 USA  
Tel: +1 (860) 355 3776  
Fax: +1 (860) 355 0712  
Email: info@visioneng.com

Vision Engineering Ltd.  
**(Central Europe)**  
Anton-Pendele-Str. 3,  
82275 Emmering, Germany  
Tel: +49 (0) 8141 40167-0  
Fax: +49 (0) 8141 40167-55  
Email: info@visioneng.de

Vision Engineering Ltd.  
**(France)**  
1 Rue de Terre Neuve, ZA Courtaboeuf,  
91967 Les Ulis Cedex, France  
Tel: +33 (0) 164 46 90 82  
Fax: +33 (0) 164 46 31 54  
Email: info@visioneng.fr

Vision Engineering Ltd.  
**(Commercial)**  
Monument House, Monument Way West,  
Woking, Surrey, GU21 5EN, England  
Tel: +44 (0) 1483 248300  
Fax: +44 (0) 1483 248301  
Email: generalinfo@visioneng.com

Vision Engineering Inc.  
**(Commercial West Coast)**  
745 West Taft Avenue, Orange,  
CA 92865 USA  
Tel: +1 (714) 974 6966  
Fax: +1 (714) 974 7266  
Email: info@visioneng.com

Nippon Vision Engineering  
**(Japan)**  
272-2 Saedo-cho, Tsuduki-ku,  
Yokohama-shi, 224-0054, Japan  
Tel: +81 (0) 45 935 1117  
Fax: +81 (0) 45 935 1177  
Email: info@visioneng.jp

Vision Engineering Ltd.  
**(Italy)**  
Via Cesare Cantù, 9  
20092 Cinisello Balsamo MI, Italy  
Tel: +39 02 6129 3518  
Fax: +39 02 6129 3526  
Email: info@visioneng.it

Vision Engineering Ltd  
**(China)**  
11J, International Ocean Building,  
720 Pudong Avenue, Shanghai,  
200120, P.R. China  
Tel: +86 (0) 21 5036 7556  
Fax: +86 (0) 21 5036 7559  
Email: info@visioneng.com.cn

Vision Engineering  
**(India)**  
Email: info@visioneng.co.in

Vision Engineering  
**(S.E. Asia)**  
Email: info@visioneng.asia

Distributor



Disclaimer - Vision Engineering Ltd. has a policy of continuous development and reserves the right to change or update, without notice, the design, materials or specification of any products, the information contained within this brochure/datasheet and to discontinue production or distribution of any of the products described.

Visit our multi-lingual website:

[www.visioneng.com](http://www.visioneng.com)